

Can-Air

Pro XL Diffuser

Industrial Diffuser

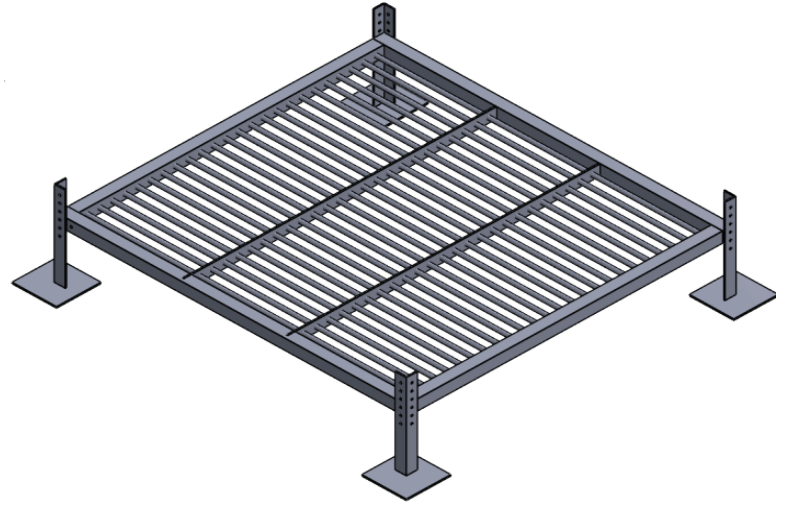

Product Features

- 100% designed & assembled in Canada
- Industrial grade, stainless steel frame
- One of the largest diffusers on the market
- Stackable design for transport
- Uses patented quality fine-bubble airline
- Long lifespan with continued high performance
- Cost effective rebuilds — every 10 years
- Unique 48-point manifold for uniform air distribution and a wide operating range
- Ships 95% assembled- Simply bolt on 4 legs
- Adjustable height

Specifications

- Dimensions: 94.0" x 88.0" (2.39 m x 2.29 m)
- Weight: 460 lb (209 kg)
- 3" x 3" x 0.25" (wall) stainless tube frame
- Diffuser surface area: 8272.0 sq in. (5.34 m²)
- 176' of 1.0" fine-bubble airline
- Airline burst pressure: 80.0 PSI above ambient
- Operating range: 30.0 – 150.0 CFM
- Optimal operating range: 35.0 – 75.0 CFM
- Requires Class 1 filtered air

Why The Pro XL Diffuser?

The Can-Air Pro XL Diffuser is one of the largest industrial diffuser on the market. Built with a stainless steel frame, Pond Pro warrants a life-time guarantee on the frame.

The Pro diffuser is cleverly designed with adjustable leg heights and pre-drilled holes for harness attachment points. A harness must be used to lower the diffuser into position. Once the diffuser is situated, its robust frame prevents the Pro XL diffuser from moving around.

With 48 air release points, this diffuser distributes air equally throughout its anti-fouling aeration airline and stainless frame. This unique Can-Air design creates one of the widest operating ranges of any diffuser with a maximum CFM rating of 150.

Why Pond Pro?

With over 20 years of experience designing and installing de-icing and aeration systems across Canada, we have perfected our Can-Air equipment to be the most easy-to-use, efficient, and reliable on the market. Pond Pro's experts can customize systems for any aeration or de-icing application!

Pond Pro